

**CBL bulb lifting clamp with extra large jaw opening**



**Properties**

- Standard with 3 pivots for extra powerful clamping force.
- Clamp is locked in closed as well as open position.
- Always equipped with a safety mechanism, ensuring the clamp does not slip when lifting force is applied and when load is being lowered.

**Application**

- For vertical lifting, handling and transporting of Holland Profile (HP) shipbuilding structures, steel plates and structures.
- Lifting of longer sections should be performed with a spreader beam fitted with multiple clamps.

**Option:**

- Higher WLL available upon request.
- Adjustable jaw opening available from: 0 to 155 mm.

**Norm:**

- EN12100-1/2, EN13155, AS4991, ASME-B30,20

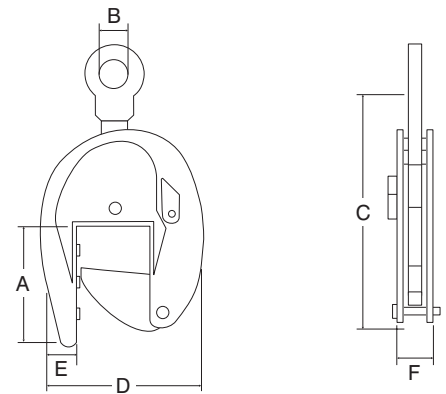

Type	WLL (kg)	Jaw opening (mm)	A (mm)	B (mm)	C (mm)	D (mm)	E (mm)	F (mm)	Weight (kg)	ProductId
CBL-1.5	1500	0-80	205	70	520	280	66	64	20	3313017

**CDK fluted sheet lifting clamps**



**Properties:**

- Capacity 3000 kg per pair.
- Always apply these clamps per pair.

**Application**

- Specifically developed for safe lifting and transportation fluted plates of dams. These clamps must always be used in pairs.

**Norm:**

- EN12100-1/2, EN13155, AS4991, ASME-B30,20

**Option**

- Schackle (3011011)

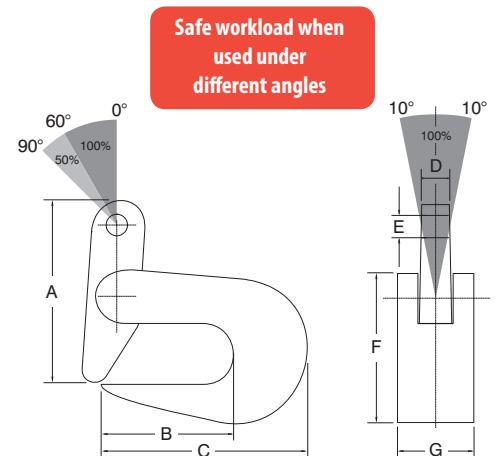

Type	WLL/pair (kg)	Jaw opening (mm)	A (mm)	B (mm)	C (mm)	D (mm)	E (mm)	F (mm)	G (mm)	Weight/pair (kg)	ProductId
CDK-3.0	3000/2	0 - 20	185	80	140	15	25	115	40	7.6	3313023